



2 Toplu hidrolik hızlı ve seri üretimler için özel üretilmiş silindirik makinesi  
2 Roll hydraulic type plate bending machine for fast and continuous  
production



- » Üst top değişken olduğundan mil ve boru takılarak istenilen üst top çapı elde edilebilir.
- » Bir kerede kıvrım yapar, verimlilik sağlar.
- » Mükemmel dairesel kıvrım yapar.
- » Malzeme üzerinde çizik ve pürüz gibi istenmeyen lekeler bırakmaz.
- » Manuel parça sürme sehpa standart olarak verilmektedir.
- » Delikli, kesik ve kabartmalı malzemeleri kıvrırabilir. Maksimum 2mm ye kadar kalın sacları hızlı şekilde kıvrırma özelliği
- » Makine hızlı ve seri üretim yapacak şekilde tasarlanmıştır.



- » The upper roll is fitted with special liners to set the required diameter.
- » Efficient output with 1 Pass rolling.
- » Perfect Round Edges after rolling.
- » No trace on materials as dust or scratches.
- » The Manual material Feeding table is delivered as standard.
- » Can bend perforated, bevelled or masked materials upto 2mm thickness without problems.
- » Machine is designed for fast and continuous production capabilities.

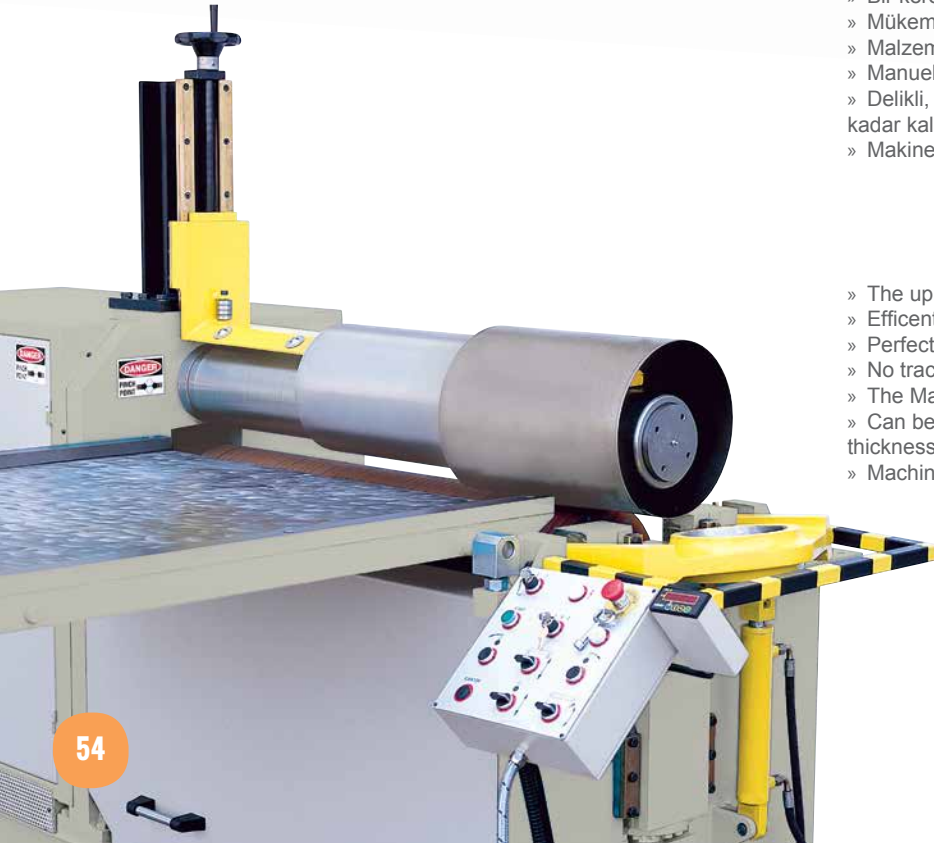

# MODEL 2R HS

2 TOPLU HİDROLİK HIZLI TİP SİLİNDİR MAKİNALARI  
2 ROLLS HYDRAULIC FAST TYPE PLATE BENDING MACHINES



2R HS	Kıvrma uzunluğu Useful length	Kıvrma kapasitesi Bending capacity	Üs top çapı Ø Upper Roll diameter Ø	Alt top çapı Ø Bottom Roll diameter Ø	Motor gücü Motor power	Uzunluk Length	Genişlik Width	Yükseklik Height	Ağırlık Weight
	mm	mm	mm	mm	kw	mm	mm	mm	kg
2R HS 1100x90	1110	1.0	90	220	2,2	2440	1550	1100	1380
2R HS 1110x185	1250	2.5	185	330	2,2	2800	1550	1100	1400

» Sac kıvrma kapasiteleri 24 kg / mm<sup>2</sup> sac mukavemetine göre verilmiştir  
» Plate bending capacities are given for 24kg / mm<sup>2</sup> plate yielding strength